

Data subject to change without prior notice
Edition 03/2020 © 2020 JMG Cranes S.p.A. All rights reserved
Rev.1 - 03/20



Electric Pick & Carry Cranes

JMG Cranes S.p.A.

Sales & Service Office
Via Bergamo, 142
26100 Cremona - Italy
t +39 0372 1786738
Production Plant
Via Sito Nuovo 14
29010 Sarmato (PC) - Italy
t +39 0523 8486
e info@jmgcranes.com

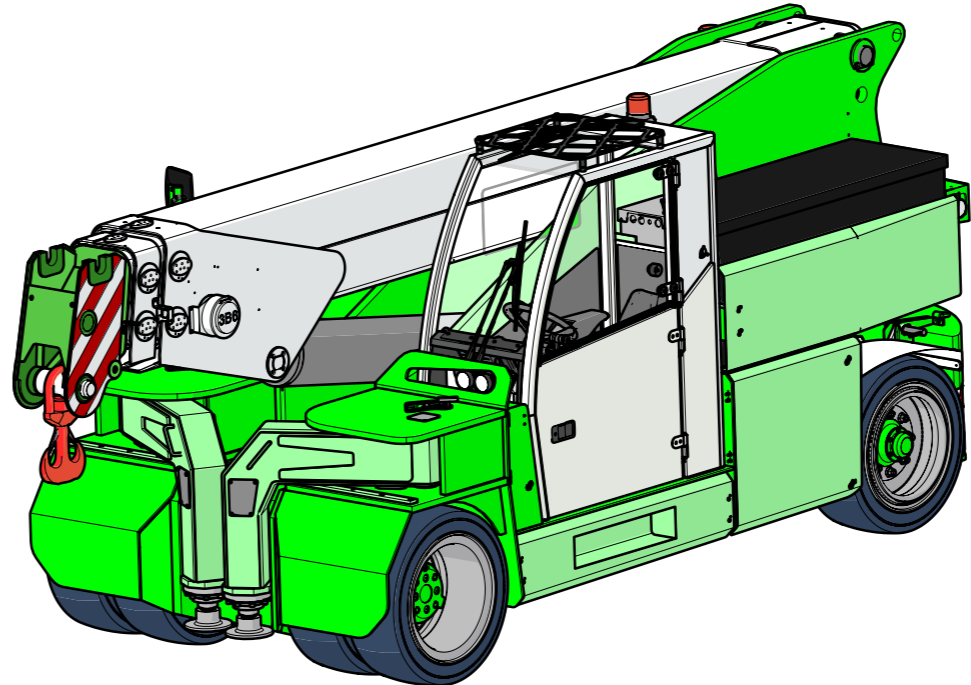

MC 250 (inch)
Max Capacity 55,000 lbs

www.jmgcranes.com





HYDRAULICALLY TELESCOPING PROPORTIONAL TYPE BOOM
FRONT-WHEELS DRIVE WITH COUNTER ROTATION
180° REAR STEERING
REMOVABLE COUNTERWEIGHTS

Options :

- HYDRAULIC WINCH
- HYDRAULIC JIB WITH HYDRAULIC EXTENSION
- BENDABLE MANUAL JIB WITH MANUAL EXTENSION
- NON-MARKING TIRES
- FRONT OUTRIGGERS
- RADIO REMOTE CONTROL
- HYDRAULIC FORKS
- MAN BUCKET
- ATEX CONVERSIONS
- CUSTOMIZED PAINTING



Technical features

Max Capacity lbs	55,000
Dimensions inch	15'8"x7'4"x7'3"

Front-wheels drive. 2 electric motors AC 12 kW 96V Insulation class H	LMI Electronic safe load indicator and tilting moment limiter
Total lbs 62,000 Removable counterweights lbs 16,200	Hydraulically foot controlled service brake on all wheels, hydraulically automatic or button controlled parking brake on front wheels
96 V - 1125 Ah 8 working hours	Fabricated from preformed and welded quality steel plate
Front nr. 4 superelastic 355/50-20" Rear nr. 2 superelastic 355/50-20"	+60°/-7°
Rear Steering angle -90°/+90°	Motor driven pump 1x23 kW - 96 V AC.

Load charts

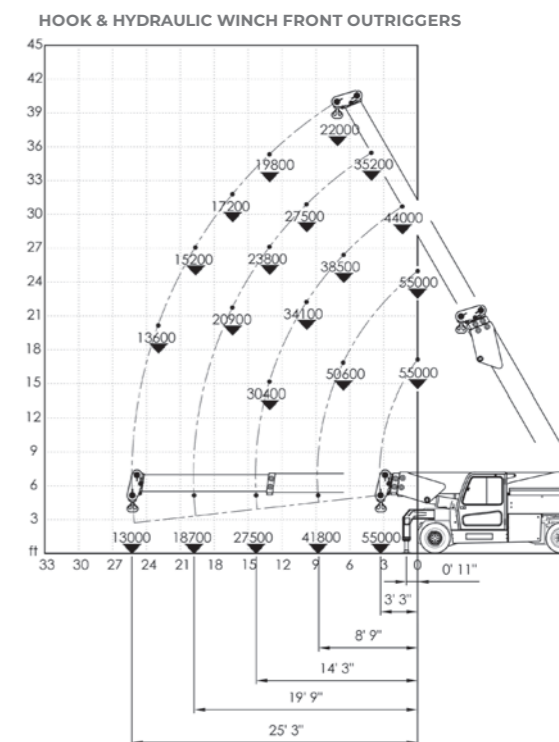
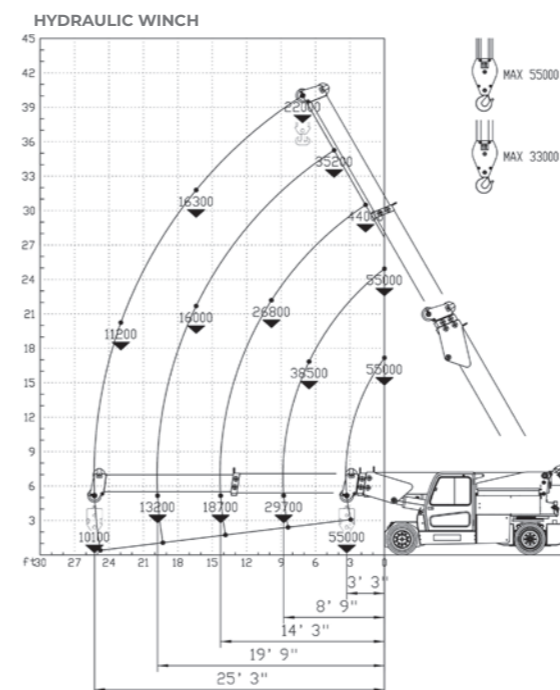
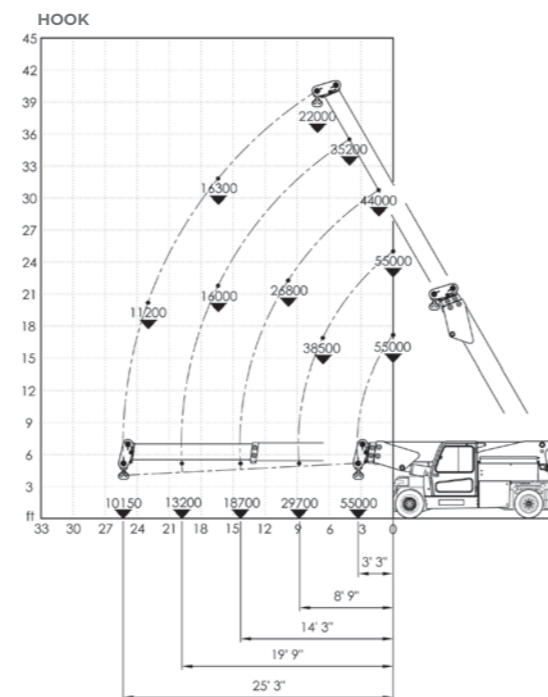

EU Standards CE

	UNI ISO 4030-1: A1
	2006/42/CE - 2000/14/CE - 2014/30 UE - 2014/35/UE - D.Lgs 262/2002 subsequent modifications
	EN 13000:2014 subsequent modifications



Dimensions

